

ESL OUTPUT

4 x Relay Expansion Board

ARROWHEAD ALARM PRODUCTS Ltd
 344b Rosedale Rd,
 Albany,
 Auckland.
 Ph. 09 414 0085
 Fax. 09 414 0088
www.aap.co.nz
 v1.0



Compatible With:

ESL, Elite S, Elite S-Lite, Elite 8D Elite-Lite, Alert 8D, Elite 16D, RX-Octa

This product is Not compatible with the ESX system.

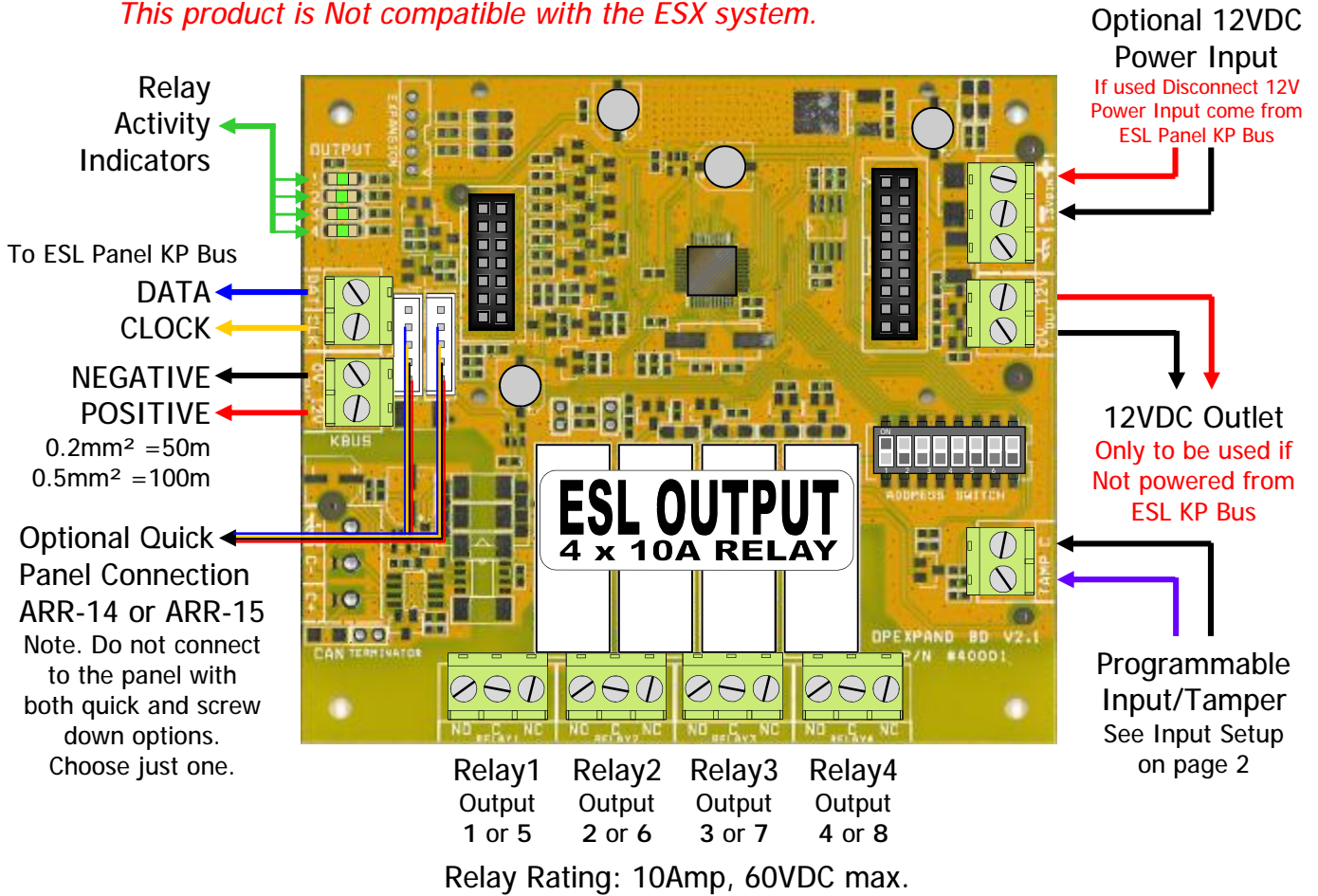

Output assignment

The ESL OX4 has 4 assignable relays, these can be set to follow outputs 1-4 or 5-8 by changing the dipswitches as outlined below.

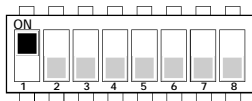

Dipswitch 1 settings

- OFF - Relay 1 follows output 1
- ON - Relay 1 follows output 5

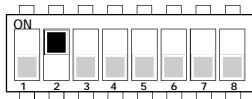

Dipswitch 2 settings

- OFF - Relay 2 follows output 2
- ON - Relay 2 follows output 6

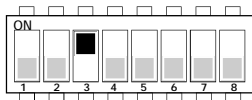

Dipswitch 3 settings

- OFF - Relay 3 follows output 3
- ON - Relay 3 follows output 7

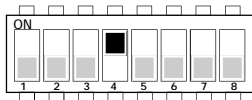

Dipswitch 4 settings

- OFF - Relay 4 follows output 4
- ON - Relay 4 follows output 8

Note. On Elite-S systems this option must be turned ON: P 25 E 10 E 6(ON)E (on by default with ESL)

Input Setup

The tamper input on the ESL OUTPUT can be configured as a standard single end of line zone or a double end of line zone with tamper. This is changed by setting dipswitch 5 as outlined below.

If dipswitch 5 is **Off** the Input can be used as a Zone, with Open, Closed and Supervised monitoring. A 2k2 resistor is used to seal the zone.

If dipswitch 5 is **On** the Input can be used as a Zone and a Tamper, with Open, Closed and Supervised monitoring. A 2k2 resistor is used to seal the tamper and a 4k7 or 8k2 resistor should be used across the normally closed zone contacts.

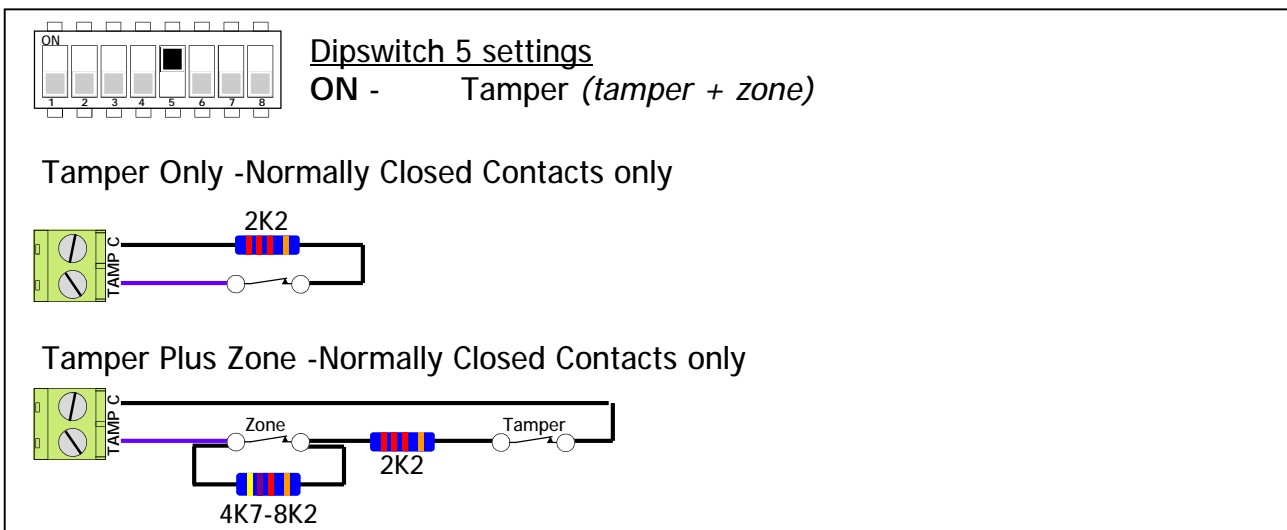
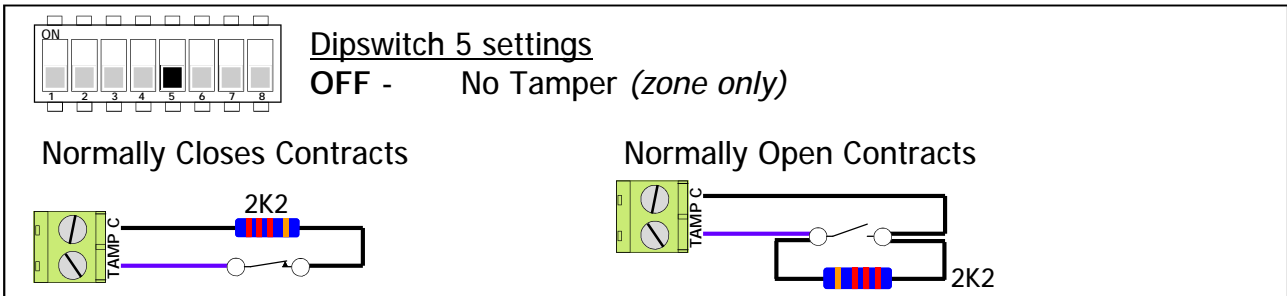

Programming Input into ESL System

The Tamper input on the ESL OUTPUT needs to be set up as a radio zone.

To learn the zone in you will need to enter Programming mode on the ESL panel.

P 164 E x E E (Where **x** = the zone number you wish to learn to)

Once the keypad starts beeping to indicate learn mode has been initiated, activate the zone or tamper to learn it in to the panel.

Next you will need to set the zone up as a radio zone.

P 122 E x E 1 & 5(on) E (Where **x** = the zone number) you should see options 1 and 5 illuminated on the keypad.

The zone must be set to freelink/freewave protocol (this is the default for ESL system)

Multiple ESL OUTPUT's

If you need more than one ESL OUTPUT on the system and are going to use the zone inputs as different zones, then you will need to change the code that the ESL OUTPUT transmits. To do this you simply need to change dipswitches 6, 7 and 8 to a different combination on each ESL OX4.

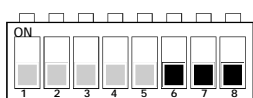

Code 1

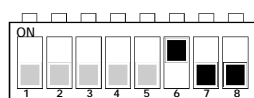

Code 2

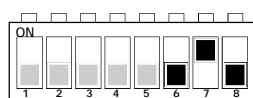

Code 3

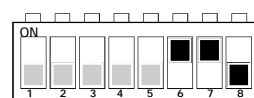

Code 4

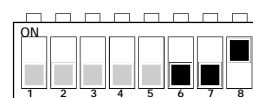

Code 5